

RECOMMENDED MOUNTING HOLE PATTERN FOR 1.60 [.063] THICK P.C. BOARD

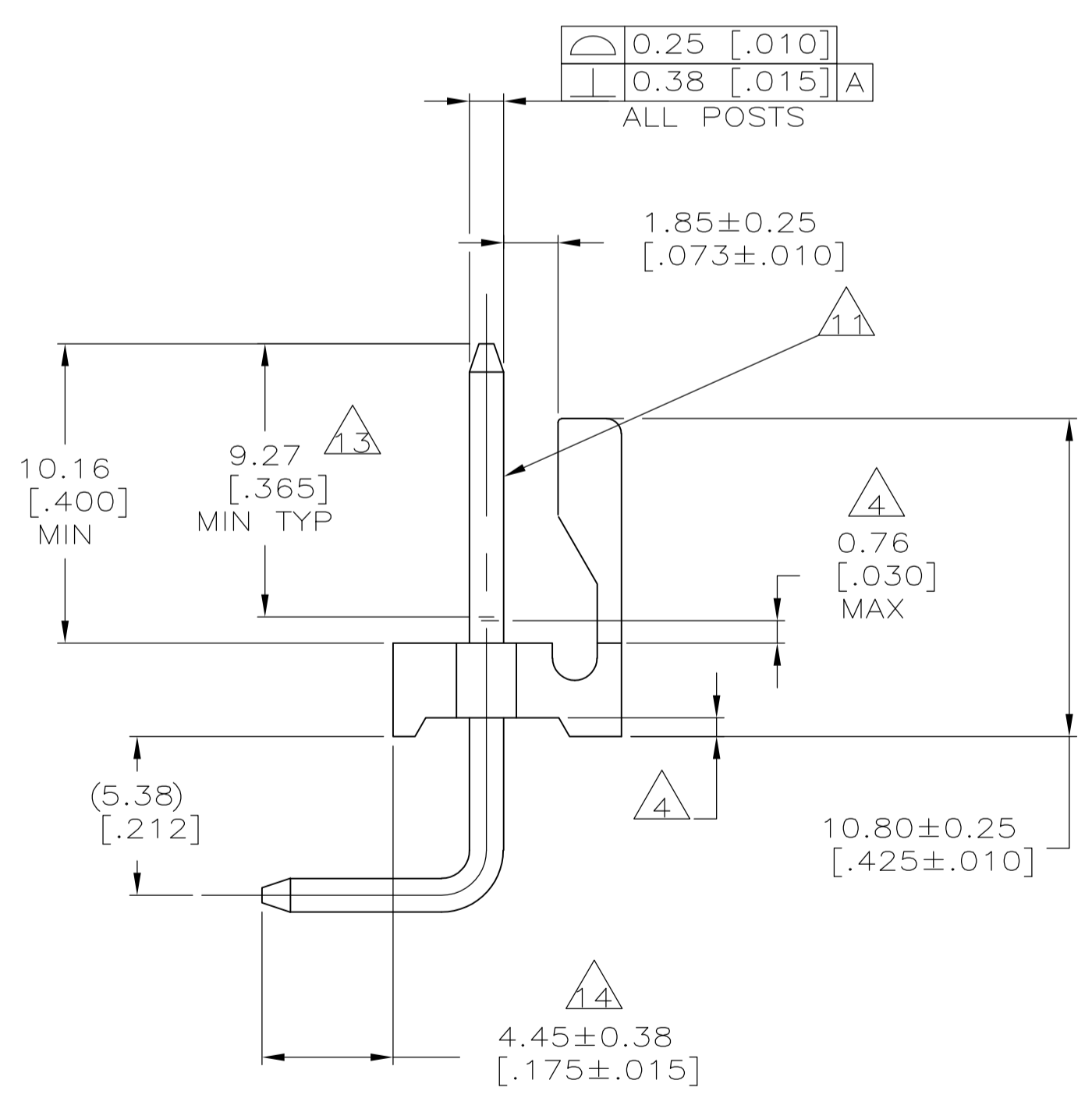
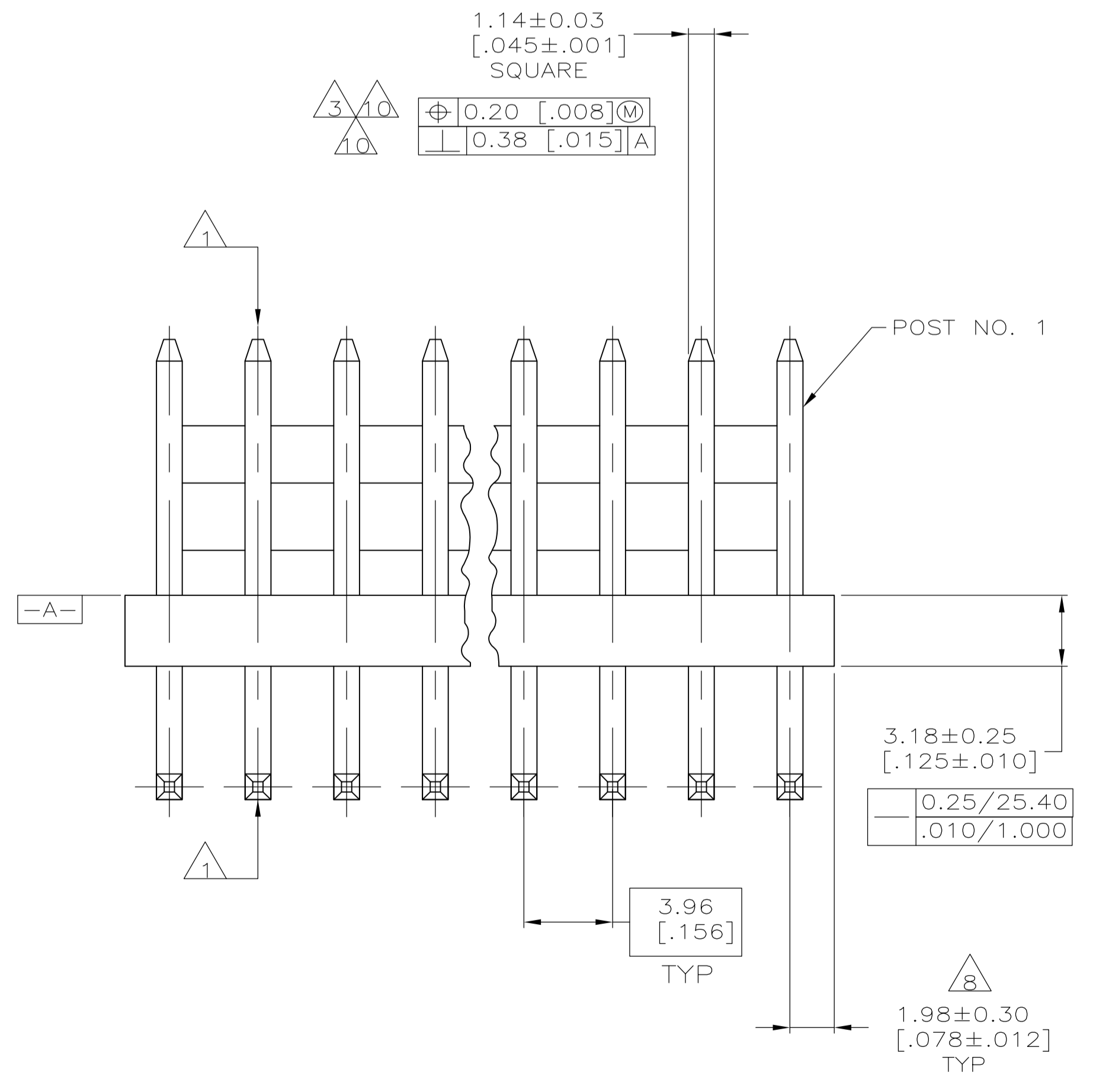
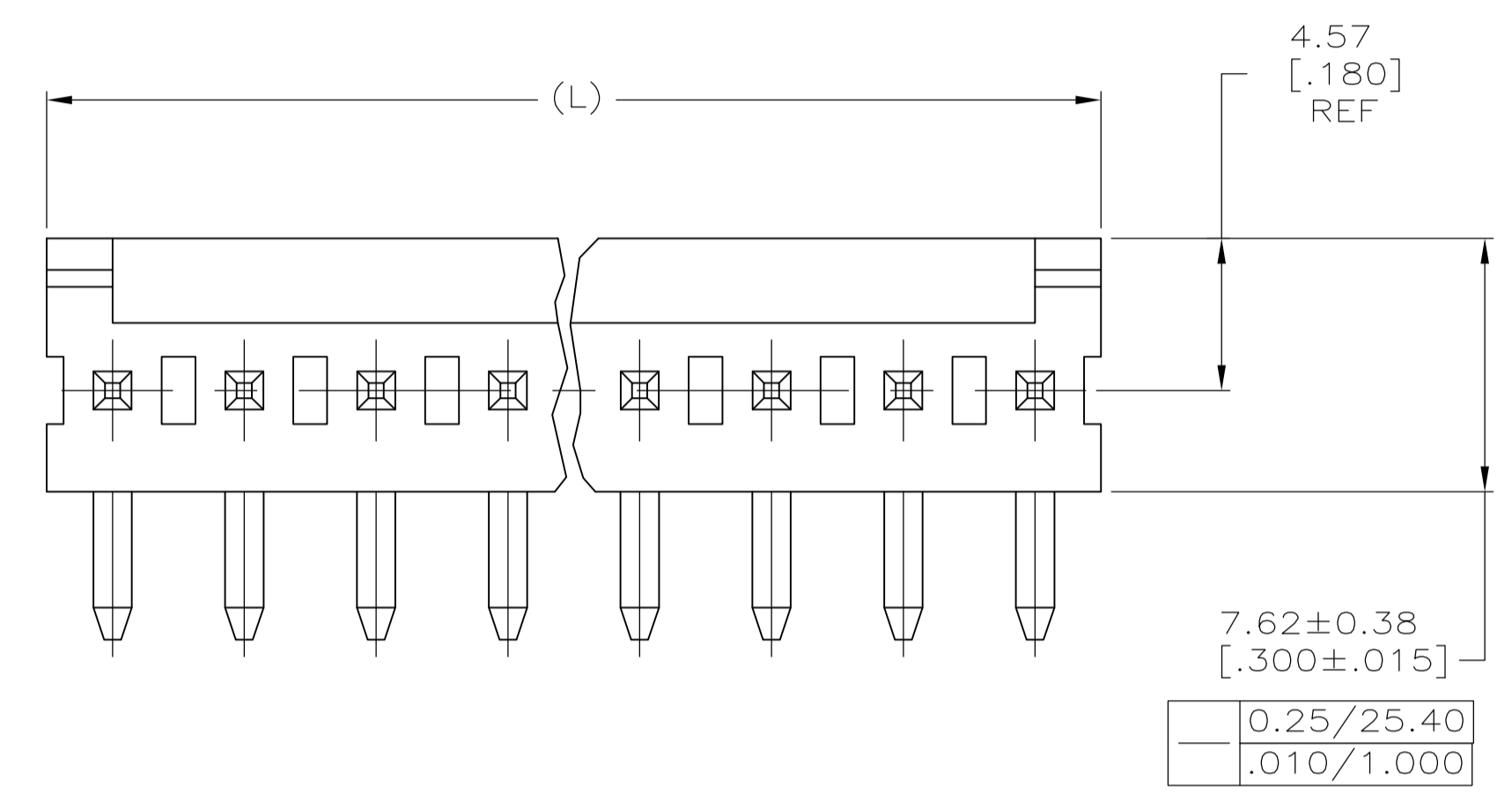

- 1 POST TO WITHSTAND 13 NEWTONS (3 LBS) MINIMUM AXIAL FORCE IN BOTH DIRECTIONS SHOWN WITHOUT DISLODGING.
- 2 TOLERANCES APPLY TO SOLDER SIDE OF BOARD.
- 3 MEASURED AT SURFACE -A-.
- 4 PLASTIC FLASH PERMITTED IN THIS AREA.
- 5 PARTS COMPLY WITH AMP SOLDERABILITY SPEC. NO. 109-11-2.
- 6 ONE HOLE MAY BE UNDERSIZED 1.65/1.52 [.065/.060] DIA. FOR ASSEMBLY RETENTION DURING WAVE SOLDERING.
- 7 MATERIAL: HEADER-THERMOPLASTIC POLYESTER GLASS-FILLED 94V-0 (NATURAL) POST-COPPER ALLOY (SEE NOTES 13 & 14 FOR PLATING)
- 8 COORDINATE DIMENSION APPLIES FROM CENTER OF ACTUAL FEATURE.
- 9. PLASTIC BURRS CAUSED BY CUT-OFF TOOLING ARE PERMITTED WITHIN THE MAXIMUM TOLERANCE ENVELOPE.
- 10 POST TO BE MEASURED WHEN STRIP IS HELD FLAT.
- 11 POST MUST WITHSTAND TWO 90° BENDS AGAINST EXTRUSION WITHOUT BREAKING.
- 12 DIMENSION SHOULD BE 8.26-10.16 [.325-.400] MIN WHEN MATING WITH A MTA-156 CONNECTOR ASSEMBLY OR 8.26-8.76 [.325-.345] MIN WHEN MATING WITH A SL-156 CONNECTOR ASSEMBLY.
- 13 PLATING: GOLD PLATE AREA, 0.00076 [.000030] MINIMUM, ALL SIDES, OVER NICKEL UNDERPLATE, 0.00127 [.000050] MINIMUM, ALL SIDES AND ENTIRE LENGTH OF POST.
- 14 PLATING: BRIGHT TIN/LEAD (93/7) PLATE AREA, 0.00381-0.00889 [.000150-.000350] THICK, ALL FOUR SIDES 4.45 [.175] MINIMUM FOR -2 THRU -24. MATTE TIN PLATE AREA 0.00381-0.00889 [.000150-.000350] THICK ALL FOUR SIDES, 4.45 [.175] FOR -32 THRU -54.

LEAD FREE	95.10 [3.744]	24	5-644761-4
	91.14 [3.588]	23	5-644761-3
	87.17 [3.432]	22	5-644761-2
	83.21 [3.276]	21	5-644761-1
	79.25 [3.120]	20	5-644761-0
	75.29 [2.964]	19	4-644761-9
	71.32 [2.808]	18	4-644761-8
	67.36 [2.652]	17	4-644761-7
	63.40 [2.496]	16	4-644761-6
	59.44 [2.340]	15	4-644761-5
	55.47 [2.184]	14	4-644761-4
	51.51 [2.028]	13	4-644761-3
	47.55 [1.872]	12	4-644761-2
	43.59 [1.716]	11	4-644761-1
	39.62 [1.560]	10	4-644761-0
	35.66 [1.404]	9	3-644761-9
	31.70 [1.248]	8	3-644761-8
	27.74 [1.092]	7	3-644761-7
	23.77 [.936]	6	3-644761-6
	19.81 [.780]	5	3-644761-5
	15.85 [.624]	4	3-644761-4
	11.89 [.468]	3	3-644761-3
	7.92 [.312]	2	3-644761-2
	DIM (L)	NO. OF POSN	ASSEMBLY

CONTAINS LEAD	95.10 [3.744]	24	2-644761-4
	91.14 [3.588]	23	2-644761-3
	87.17 [3.432]	22	2-644761-2
	83.21 [3.276]	21	2-644761-1
	79.25 [3.120]	20	2-644761-0
	75.29 [2.964]	19	1-644761-9
	71.32 [2.808]	18	1-644761-8
	67.36 [2.652]	17	1-644761-7
	63.40 [2.496]	16	1-644761-6
	59.44 [2.340]	15	1-644761-5
	55.47 [2.184]	14	1-644761-4
	51.51 [2.028]	13	1-644761-3
	47.55 [1.872]	12	1-644761-2
	43.59 [1.716]	11	1-644761-1
	39.62 [1.560]	10	1-644761-0
	35.66 [1.404]	9	644761-9
	31.70 [1.248]	8	644761-8
	27.74 [1.092]	7	644761-7
	23.77 [.936]	6	644761-6
	19.81 [.780]	5	644761-5
	15.85 [.624]	4	644761-4
	11.89 [.468]	3	644761-3
	7.92 [.312]	2	644761-2
	DIM (L)	NO. OF POSN	ASSEMBLY

**METRIC**

THIS DRAWING IS A CONTROLLED DOCUMENT.

DIMENSIONS: mm [INCHES]	TOLERANCES UNLESS OTHERWISE SPECIFIED:	DWN: S. HOOVER 07NOV02	CHK: D. BOSSI 07NOV02	APPRO: D. BOSSI 07NOV02	NAME: Tyco Electronics Corporation Harrisburg, PA 17105-3608
0 PLC ± -	1 PLC ± -	2 PLC ± 0.13[.005]	3 PLC ± -	4 PLC ± -	ANGLES ± -
MATERIAL: 1	FINISH: 1	SIZE: A1	DWG CODE: 00779	DRAWING NO: 644761	RESTRICTED TO: -
CUSTOMER DRAWING		SCALE: 5:1	SHEET: 1 of 1	REV: D	